

SILO TEMPERATURE SENSOR - WATERTIGHT IP65 TER-616/T

To be installed inside the silo higher room, where air is clean. It signals an overheating state caused by an ongoing or a smoldering fire. Its NO normally open contact will close when the temperature reaches 88°C (190°F), and it will return back to the open state as soon as the temperature decreases below 88°C (190°F). It needs a power supply voltage of 24VDC and it is used to control an optical and acoustical alarm signal. The protection level is IP65 (watertight) and its output is by free leads. Two holes in the base are provided for wall mounting by two M5 screws.

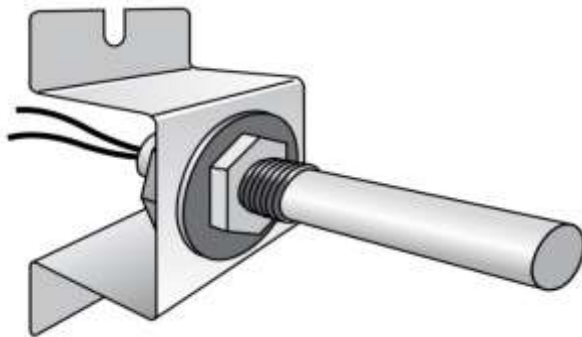

Important warning!

Do not force the sensor rod in order to avoid temperature setting changes or sensor damage. During the installation use a hexagonal key to block the hexagonal head.

Specifications

- Type of contact: NO Normally Open.
- It closes at 88°C (190°F), and reopens below 88°C (190°F).
- Contact rating 0.5A 24VDC (max voltage 32VDC).
- Electrical connections by two free leads, 300mm in length.
- IP65 protection (watertight). It needs an external IP65 junction box, not supplied.
- Mechanical mounting by two M5 screws on the mounting bracket.
- Centre hole distance 76mm.
- Mounting bracket dimensions 86x36x46mm.
- Sensor total length 136mm, double thread 1/2" NPT.
- Sensor rod diameter 16mm, length 77mm.
- Sensor weight 80gr.
- Sensor rod material stainless steel, mounting head brass.
- Working temperature -40 +125°C (-40 +257°F).
- Protected area 120 square meters.
- Packaging mm 130x85x65.
- Weight: 180gr (220gr with packaging).

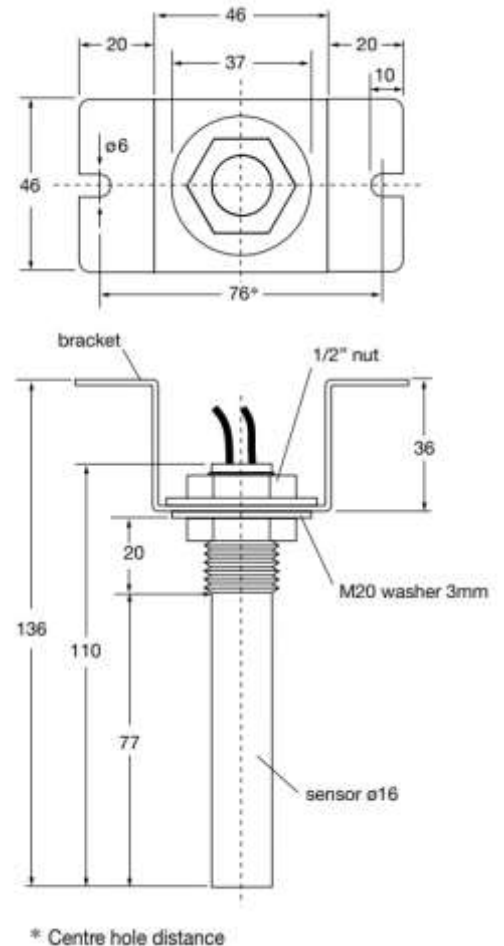

System connections

